

SPECIFICATIONS TECHNIQUES CLIENT

Corps de boîte ronde S.E. Ø 71 x 138 C6

Format Ø 71 x 138

Capacité 500 ml

Dimensions (mm)

Dimensions intérieures Ø 71
Hauteur 138,35 ± 0.6



		<i>Corps</i>	<i>Dessus</i>	<i>Fond</i>
<u>Métal</u>	Type /temper	TS275	TS275	TH435
	Epaisseur	0.22 mm	0.28 mm	0.22 mm
	Etamage int /ext	E 2,8 / 2,8 g/m2	D 2,8 / 5,6 g/m2	E 5,6 / 5,6 g/m2
<u>Vernis</u>	Intérieur	Nu	Nu	Nu
	Extérieur	Nu ; ou impression + vernis sur impression Alkyde	Nu	Nu

Emballage

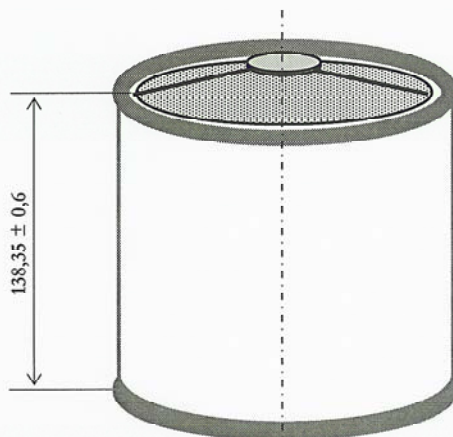
Dimensions palette 1420 x 1120
Boîtes par lit 315
Nbre. de lits 9
Nbre. de boîtes / palette 2 835

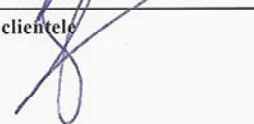

Date de mise à jour : 29 / 04 / 2008

Méthodes Visa 	Contrôle qualité Visa : 	Relation technique clientèle Visa : 
--	--	--

SPECIFICATIONS TECHNIQUES CLIENT

Bouchon C6 Ø 24

Dimensions (mm)

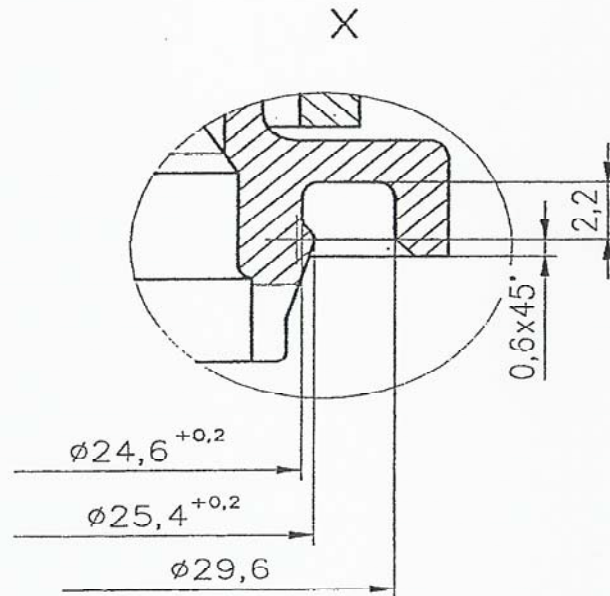
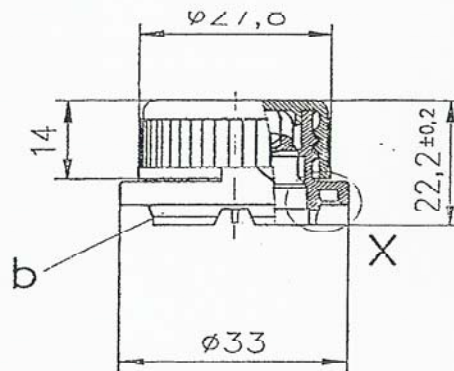

Date de mise à jour : 29 / 04 / 2008

Méthodes Visa : 	Contrôle qualité Visa : 	Relation technique clientèle Visa : 
--	--	--